

DVT-FP250 Probe Positioner

Quick, Steady Precision Hands-Free Probing with VNA or TDR Instruments

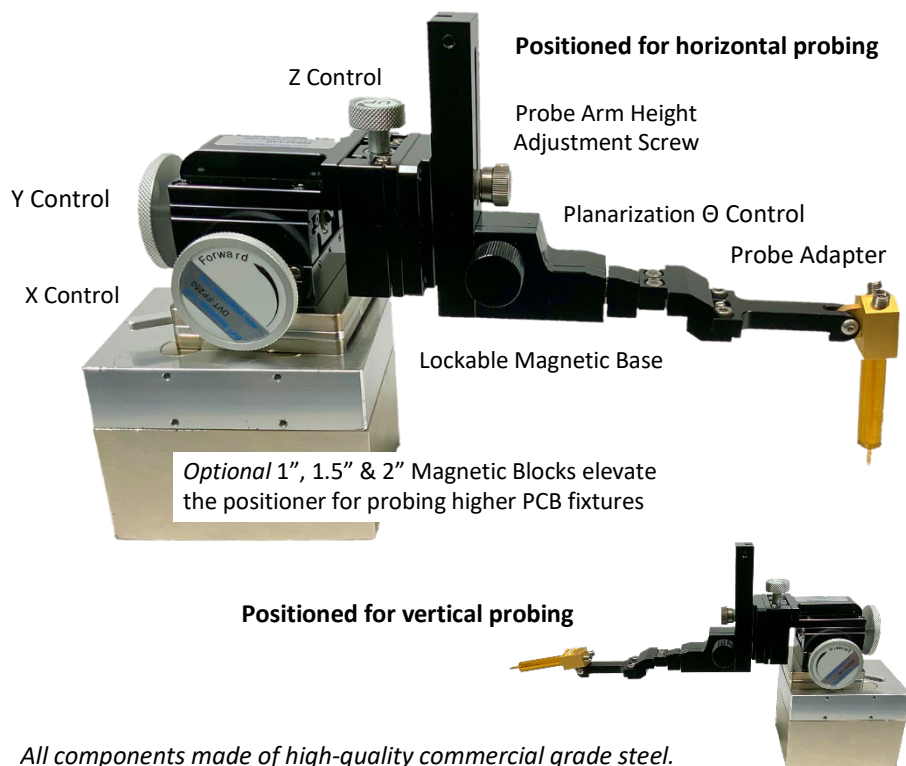

- ### Features
- XYZ-axis travel: 16 mm with 500 um/turn (50 TPI)
 - Θ control: $\pm 10^\circ$ with $2.5^\circ/\text{turn}$ and 0.025° resolution
 - Length: 228 mm/9.5 in
 - Width: 68 mm/2.7 in
 - Height: 108 mm/4.3 in
 - Weight: 2702 grams/5 lb. 15.4 oz
 - Base: Steel with lockable magnetic bottom
 - Height Coarse Adjustment: 5 mm/step (14 steps)
 - Straight Arm: Horizontal or Vertical Probing
 - Probe Arm Adapters:
 - GigaProbes® DVT40, DVT30 and DVT-FPP40-70 GHz
 - FormFactor, GGB, Ind & SE Probes

Applications

Single-Ended: Power Integrity, DDR memory and Impedance analysis

Differential: TDR/VNA S-Parameter or Impedance measurements on Packages, PCBs and backplane systems

Horizontal or Vertical Probing Systems

The DVT-FP250 is a fixed-arm positioner with high-precision XYZ controls used to line up the probe's tips to the test pads, and a Planarization Control to ensure that both probe tips make contact with the test pads evenly for accurate and repeatable probing.

These precision controls are essential for microwave and package probing and the versatility required for probing large or small PCB's.

The straight probe arm can probe Horizontal PCBs and the Probe Arm Height Adjustment Screw can be used to probe a vertically mounted PCB.

The large control wheels quickly move the probe arm to reduce user fatigue making it an ideal positioner for Failure Analysis, Flex, Device Packages, or other PCB interconnects where extensive waveform probing is required.

Adapters



Probe Compatibility

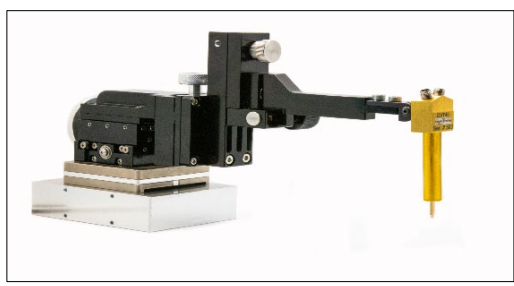

Horizontal Probing

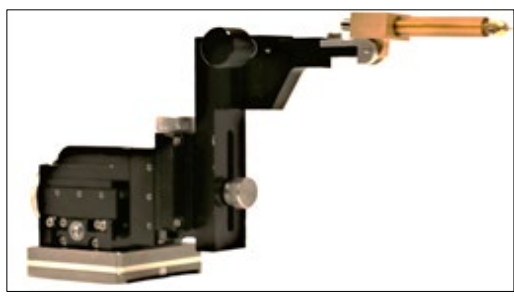

Vertical Probing



SEprobes Fixed Pitch Single Ended Probes

Single Ended Fixed Pitch Probes (SEprobes) for Power Integrity measurements or DDR memory interconnect analysis.

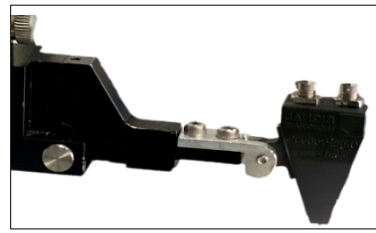

Differential Fixed Pitch 40 GHz & 70 GHz Probes



Strong design: Mount TDR modules directly to probes attached to the end of a DVT-FP250 Probe Positioner to maintain TDR rise time.



FormFactor, GGB Industries
18 GHz-70 GHz 50um to
250um probes for package
or die probing

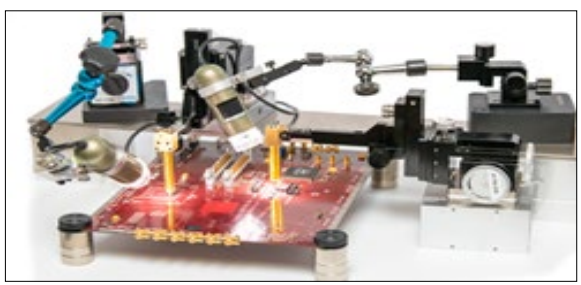

Dual VNA Horizontal 4-port probe system: Contains two DVT40 40 GHz differential probes attached to two DVT-FP250 Probe Positioners, with a CS3 Camera System used to view the probe tips.

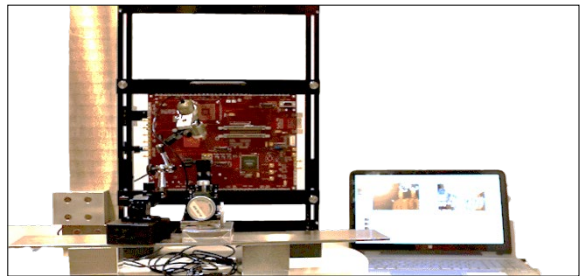

Dual VNA Vertical 4 port VNA probe system: contains two DVT40 40 GHz differential probes installed in two DVT-FP250 Probe Positioners and a CS3 Camera System to view probe tips. A Probe Bridge is used to raise the DVT-FP250 to reach probing test pads.

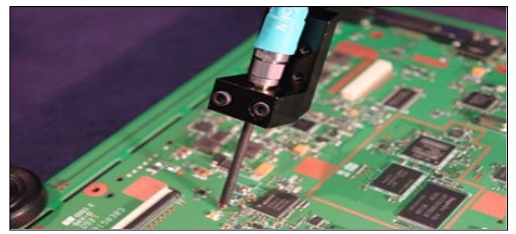

High Bandwidth Differential Probe system:
A DVT-FPPXX (xx=40 GHz, 50 GHz or 70 GHz bandwidth probe) is attached to the adapter and to the end of the Probe Positioner arm.

